



## Technical Data Sheet

### TOP View LEDs With Lens (Preliminary)

#### 67-11B/T7C-MX1Y2M/BT

#### Features

- PLCC-2 package.
- High flux output.
- High current capability.
- White package.
- Optical indicator.
- Colorless clear window.
- Ideal for backlight and light pipe application.
- Inter reflector.
- Suitable for automatic placement equipment.
- Suitable for reflow and wave solder processes.
- Available on tape and reel (12mm Tape).
- Pb-free.
- The product itself will remain within RoHS compliant version.



#### Descriptions

The 67-21B series is available in soft orange, red and yellow. Due to the package design, the LED has wide viewing angle and optimized light coupling by inter reflector. This feature makes the 67-21B series LED ideal for light pipe application. The low current requirement makes this device ideal for portable equipment or any other application where power is at a premium.

#### Applications

- Indicator and backlight for audio and video equipment.
- Indicator and backlight in office and family equipment.
- Flat backlight for LCD's, switches and symbols.
- Light pipe application.
- General use.

#### Device Selection Guide

Chip		Lens Color
Material	Emitted Color	
InGaN	Pure White	Water Clear

**Package Dimensions**

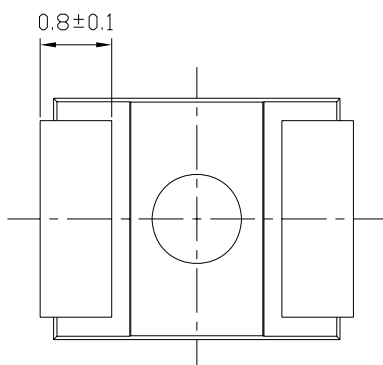
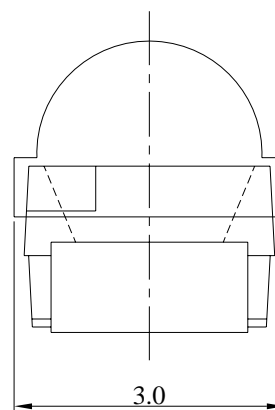
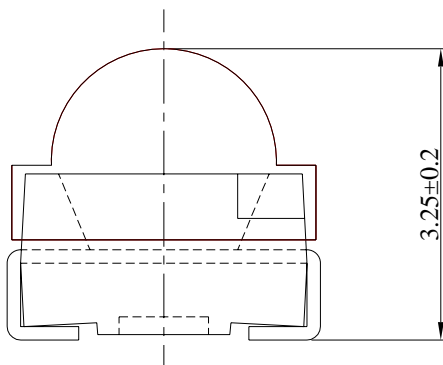
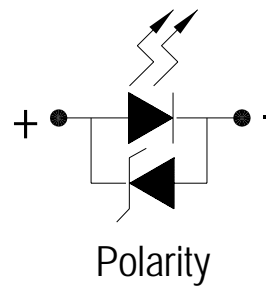
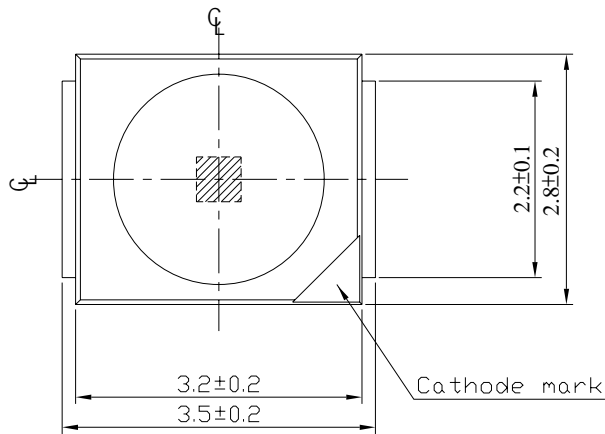

For reflow soldering (propose)

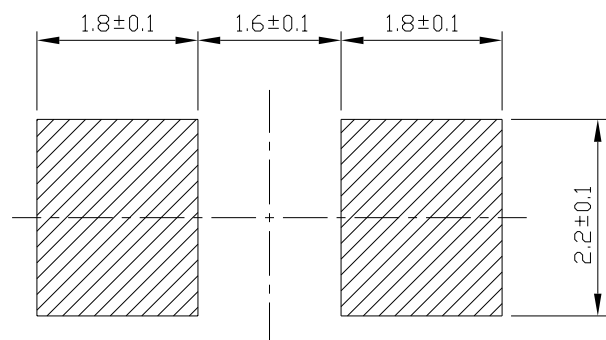

**Note:** The tolerances unless mentioned is  $\pm 0.1$ mm ,Unit = mm

**67-11B/T7C-MX1Y2M/BT****Absolute Maximum Ratings ( $T_a=25^\circ\text{C}$ )**

Parameter	Symbol	Rating	Unit
Reverse Voltage	$V_R$	5	V
Forward Current	$I_F$	30	mA
Operating Temperature	Topr	-40 ~ +85	$^\circ\text{C}$
Storage Temperature	Tstg	-40~ +90	$^\circ\text{C}$
Electrostatic Discharge (HBM)	ESD	2000	V
Power Dissipation	Pd	110	mW
Peak Forward Current(Duty 1/10 @ 1KHz)	$I_{FP}$	100	mA
Soldering Temperature	Tsol	Reflow Soldering : 260 $^\circ\text{C}$ for 10 sec. Hand Soldering : 350 $^\circ\text{C}$ for 3 sec.	

**Electronic Optical Characteristics ( $T_a=25^\circ\text{C}$ ) :**

Parameter	Symbol	Min.	Typ.	Max.	Unit	Condition
Luminous Intensity	$I_v$	1800	-----	3600	mcd	$I_F=20\text{mA}$
Viewing Angle	$2\theta$	-----	60	-----	deg	$I_F=20\text{mA}$
Forward Voltage	$V_F$	2.75	-----	3.95	V	$I_F=20\text{mA}$

## Notes:

- 1.Tolerance of Luminous Intensity  $\pm 10\%$
- 2.Tolerance of Forward Voltage  $\pm 0.1\text{V}$



**67-11B/T7C-MX1Y2M/BT**

**Bin Range Of Dom. Wavelength**

Groups	Min	Max	Unit	Condition
X1	1800	2250	mcd	IF=20mA
X2	2250	2850		
Y1	2850	3600		
Y2	3600	4500		

**Bin Range Of Forward Voltage**

Groups	Bin	Min	Max	Unit	Condition
M	5	2.75	3.05	V	IF=20mA
	6	3.05	3.35		
	7	3.35	3.65		
	8	3.65	3.95		

Notes:

- 1.Tolerance of Luminous Intensity  $\pm 10\%$
- 2.Tolerance of Forward Voltage  $\pm 0.1V$

Chromaticity Coordinates Specifications for Bin Grading

Group	Bin Code	CIE_x	CIE_y	Bin Code	CIE_x	CIE_y
M	B5-1	0.291	0.286	B5-3	0.296	0.276
		0.287	0.295		0.292	0.286
		0.297	0.305		0.300	0.295
		0.300	0.295		0.304	0.285
	B5-2	0.300	0.295	B5-4	0.304	0.285
		0.297	0.305		0.300	0.295
		0.307	0.315		0.309	0.305
		0.309	0.305		0.311	0.294
	A0-1	0.272	0.258	A0-3	0.280	0.248
		0.264	0.267		0.272	0.258
		0.276	0.281		0.282	0.272
		0.282	0.272		0.288	0.262
	A0-2	0.282	0.272	A0-4	0.288	0.262
		0.276	0.281		0.282	0.272
		0.287	0.295		0.292	0.286
		0.292	0.286		0.296	0.276

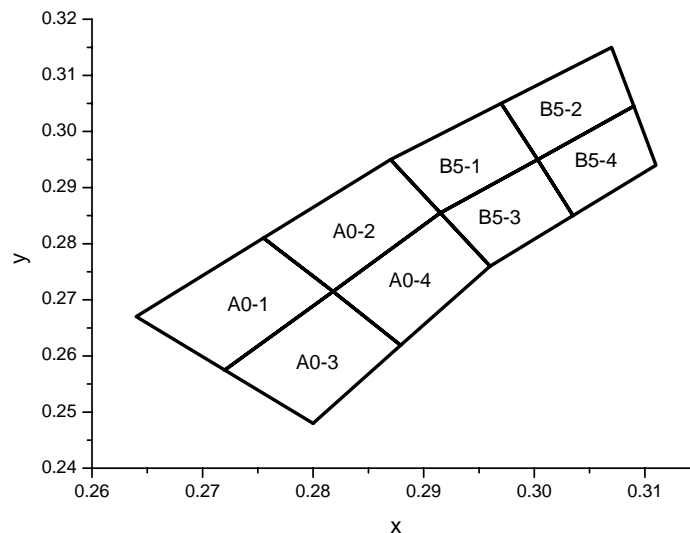

**Typical Electro-Optical Characteristics Curves**

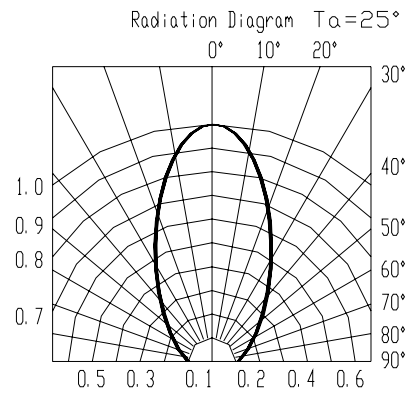
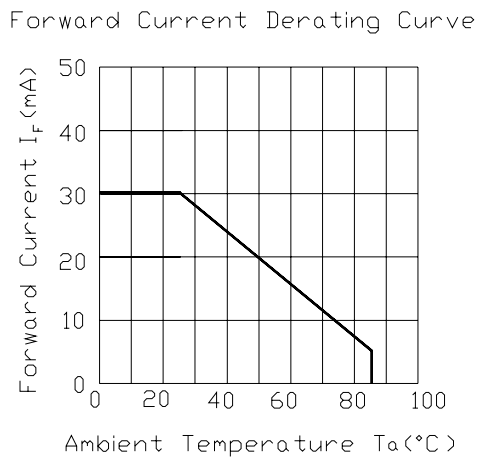
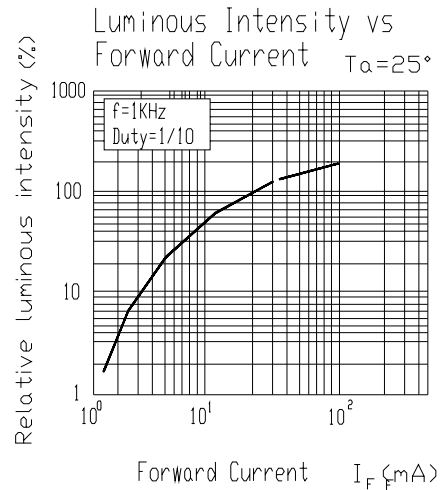
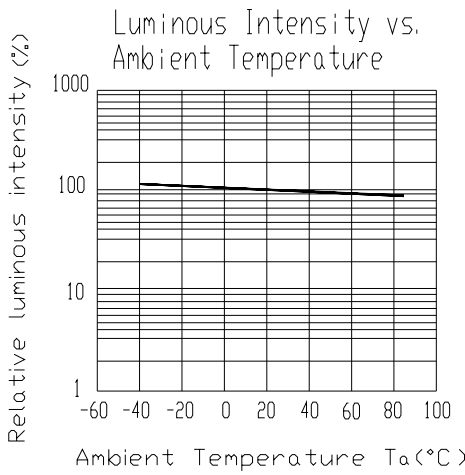
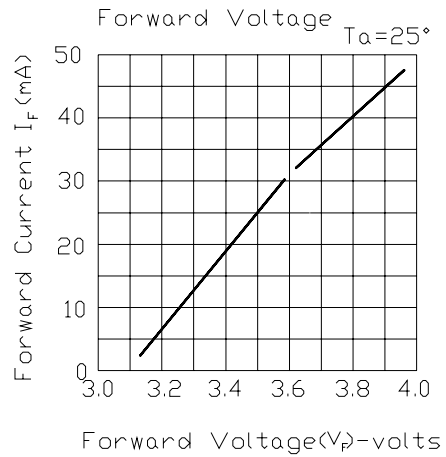
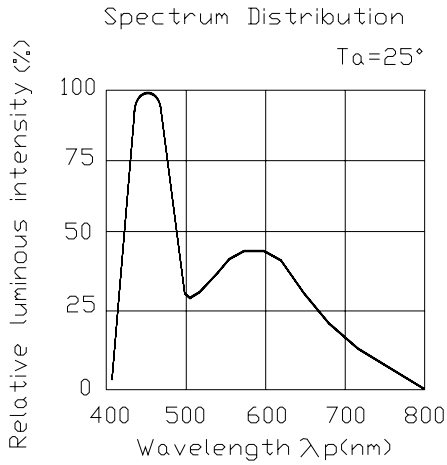

**Label explanation**

**CAT: Luminous Intensity Rank**

**HUE: Chromaticity Coordinates**

**REF: Forward Voltage Rank**

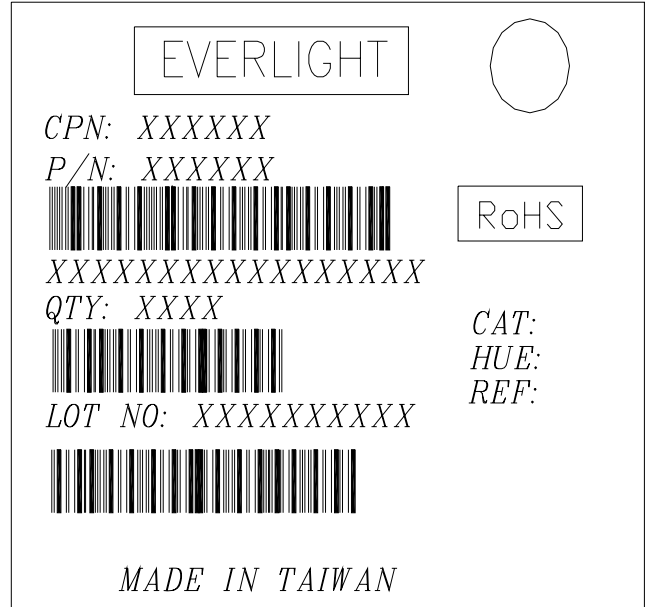

**Reel Dimensions**

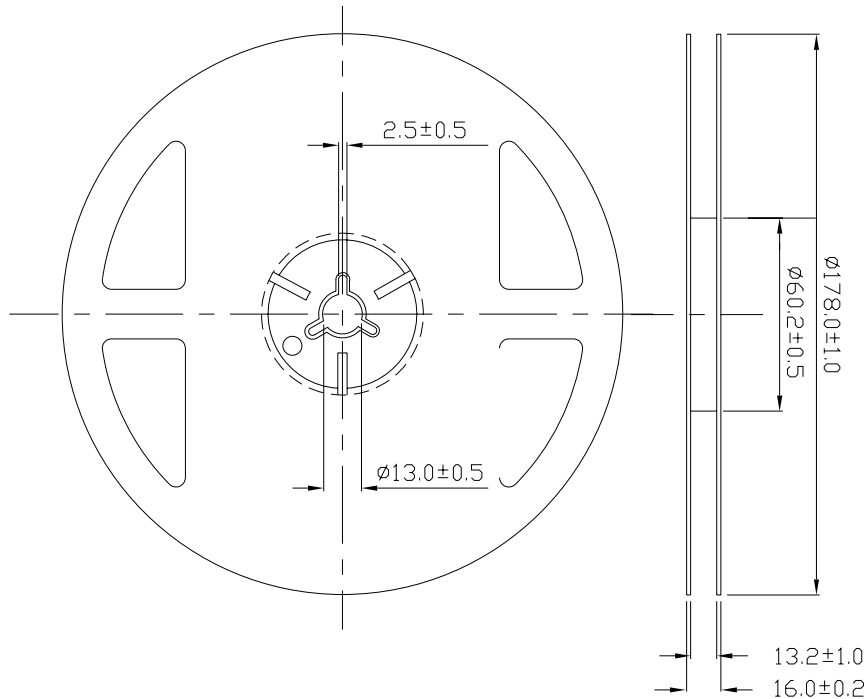

**Note:** The tolerances unless mentioned is  $\pm 0.1\text{mm}$  ,Unit = mm

**Carrier Tape Dimensions: Loaded quantity 500 PCS per reel.**

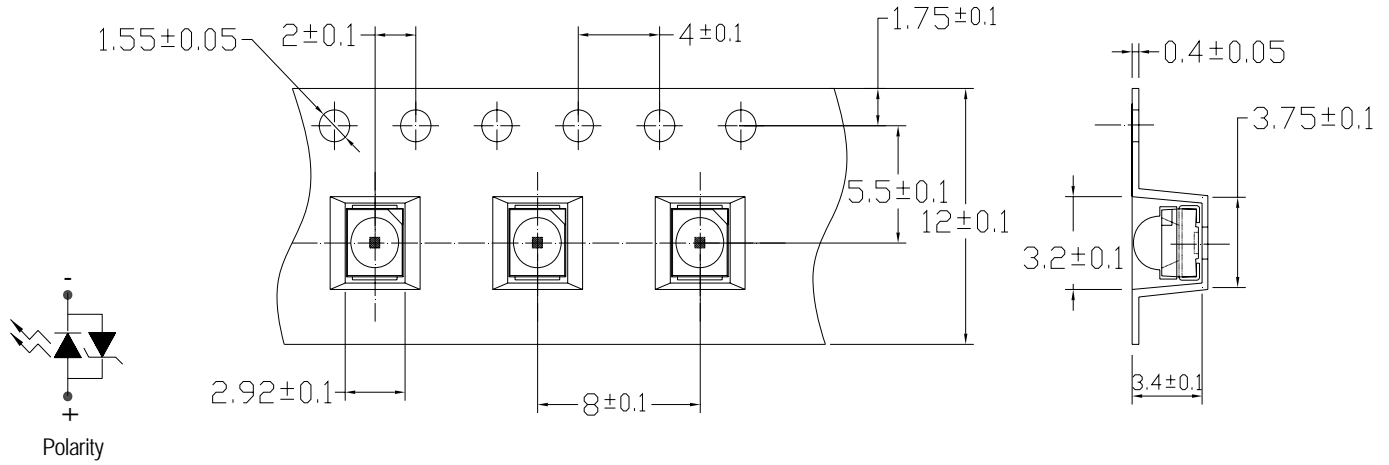

**Note: The tolerances unless mentioned is ±0.1mm Unit = mm**

**Moisture Resistant Packaging**

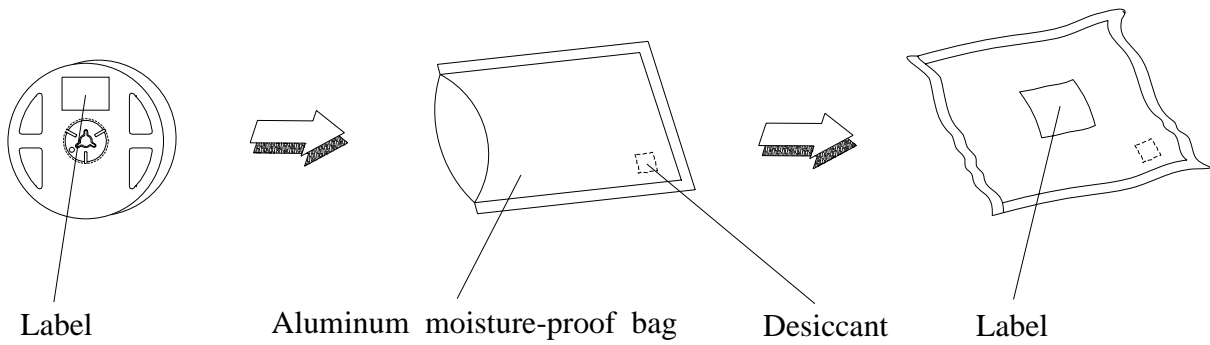



**Reliability Test Items And Conditions**

The reliability of products shall be satisfied with items listed below.

Confidence level : 90%

LTPD : 10%

No.	Items	Test Condition	Test Hours/Cycles	Sample Size	Ac/Re
1	Reflow Soldering	Temp. : 260°C ±5°C Min. 5sec.	6 Min.	22 PCS.	0/1
2	Temperature Cycle	H : +100°C 15min ∫ 5 min L : -40°C 15min	300 Cycles	22 PCS.	0/1
3	Thermal Shock	H : +100°C 5min ∫ 10 sec L : -10°C 5min	300 Cycles	22 PCS.	0/1
4	High Temperature Storage	Temp. : 100°C	1000 Hrs.	22 PCS.	0/1
5	Low Temperature Storage	Temp. : -40°C	1000 Hrs.	22 PCS.	0/1
6	DC Operating Life	IF = 20 mA	1000 Hrs.	22 PCS.	0/1
7	High Temperature / High Humidity	85°C / 85%RH	1000 Hrs.	22 PCS.	0/1

## Precautions For Use

### 1. Over-current-proof

Customer must apply resistors for protection, otherwise slight voltage shift will cause big current change ( Burn out will happen ).

### 2. Storage

2.1 Do not open moisture proof bag before the products are ready to use.

2.2 Before opening the package: The LEDs should be kept at 30°C or less and 90%RH or less.

2.3 After opening the package: The LED's floor life is 1 year under 30°C or less and 60% RH or less.

If unused LEDs remain, it should be stored in moisture proof packages.

2.4 If the moisture absorbent material (silica gel) has faded away or the LEDs have exceeded the storage time, baking treatment should be performed using the following conditions.

Baking treatment : 60±5°C for 24 hours.

### 3. Soldering Condition

#### 3.1 Pb-free solder temperature profile

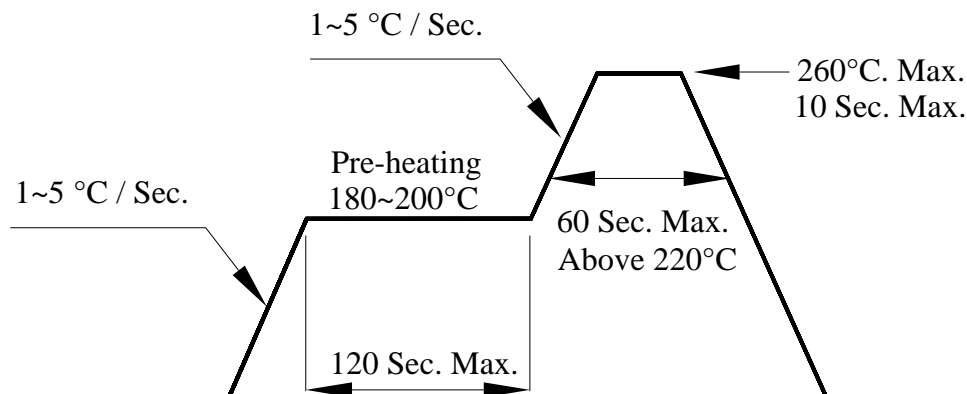

3.2 Reflow soldering should not be done more than two times.

3.3 When soldering, do not put stress on the LEDs during heating.

3.4 After soldering, do not warp the circuit board.

### 4. Soldering Iron

Each terminal is to go to the tip of soldering iron temperature less than 350°C for 3 seconds within once in less than the soldering iron capacity 25W. Leave two seconds and more intervals, and do soldering of each terminal. Be careful because the damage of the product is often started at the time of the hand solder.

### 5.Repairing

Repair should not be done after the LEDs have been soldered. When repairing is unavoidable, a double-head soldering iron should be used (as below figure). It should be confirmed beforehand whether the characteristics of the LEDs will or will not be damaged by repairing.

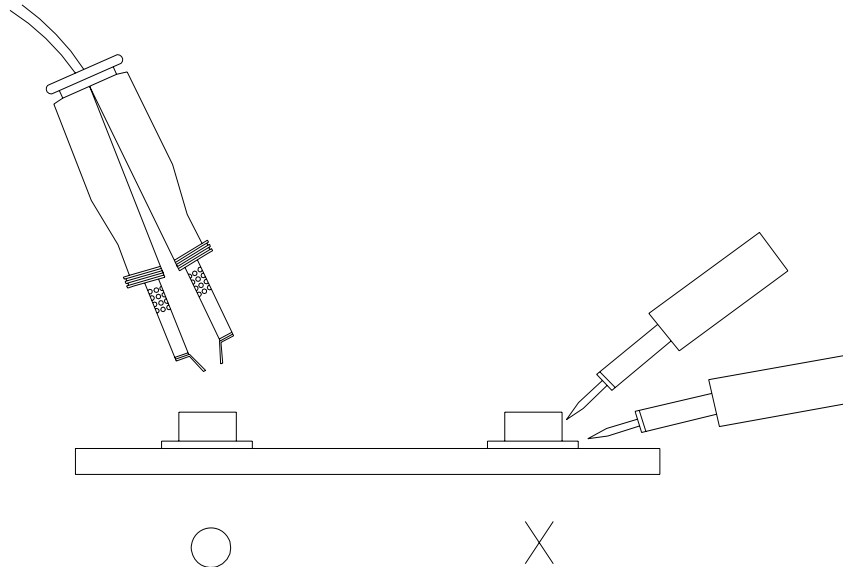

**EVERLIGHT ELECTRONICS CO., LTD.**  
Office: No 25, Lane 76, Sec 3, Chung Yang Rd,  
Tucheng, Taipei 236, Taiwan, R.O.C

Tel: 886-2-2267-2000, 2267-9936  
Fax: 886-2267-6244, 2267-6189, 2267-6306  
<http://www.everlight.com>